



SMR DRIVE



Shaft Mounted Reducer

Cyclo Transmissions Ltd., a leading manufacturer of various types of speed reducers introduces a new product Shaft Mounted Reducer (SMR).

SMR can be directly mounted on the drive shaft of the equipment to be driven. The direct mounting principle assures correct alignment and reduces foundation, couplings, etc. A torque-arm anchors the reducers and provides quick, easy adjustment of the wedge belts by means of its turnbuckle. SMR is manufactured in seven different sizes, and the Model No. is specified with respect to its rated torque capacity in Kg-m. The reduction ratios available are 5:1, 13:1 & 20:1. A very wide choice of output speeds can be determined by the use of an appropriate input belt drive.

Design Features

The SMR have distinct design and manufacturing featuring giving long-life performance.

Gears : The helical case carburised and ground gears are designed for optimum wear resistance & strength, made from high alloy steel materials. Exacting quality standards throughout the manufacturing ensures the maximum working life.

Shafts : Hollow Output Shafts having through keyway are manufactured from high carbon steel and conforms to Indian Standards and Input shaft is integral part of pinion gear and manufactured from high-grade alloy steel.

Casings : Casing made from close grain cast iron accurately machined to ensure interchangeability and. proper alignment of the gears and shaft.

Torque-Arm Mounting : Two positions are provided as per direction of rotation of Output Shaft for the mounting of torque-arm to have an advantage of universal mounting.

Dimension Sheet

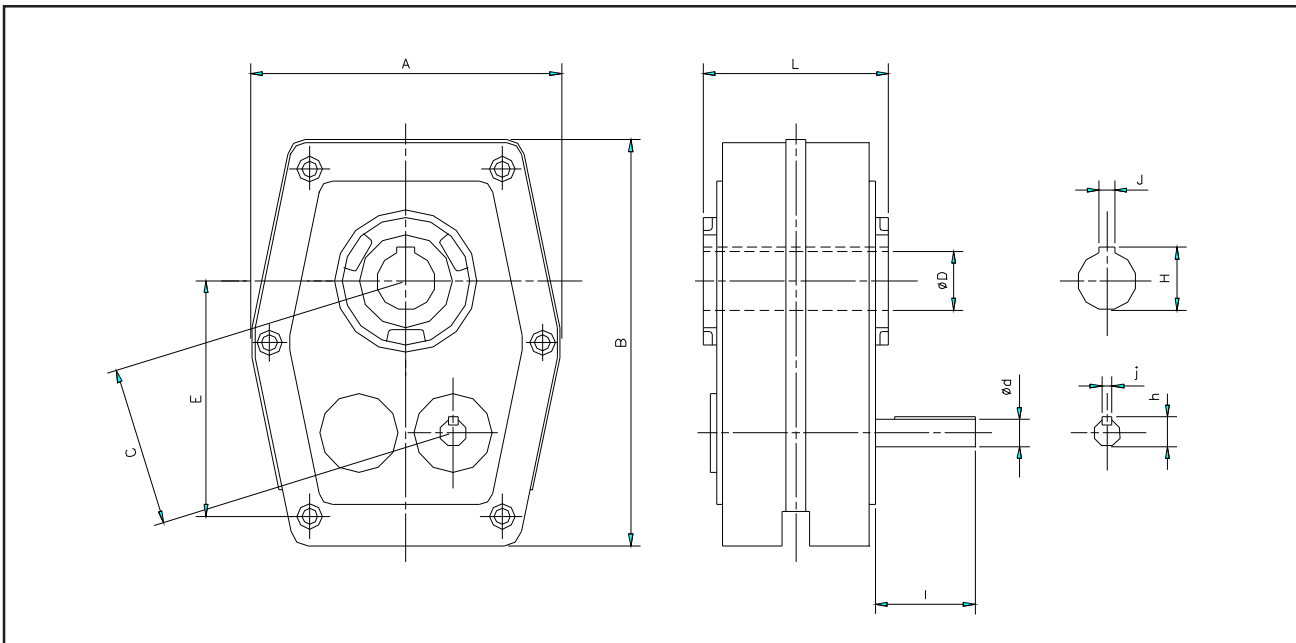

SIZE	H	W	D	ϕG	L	ϕB	M	X	Approx wt. (kg)	
									5.1	13-20 ratio
SMR 20	208	160	117	14	51	30	70	123	10	11
SMR 30	226	186	134	19	63	30	79	131	15	16
SMR 50	270	218	142	22	72	40	95	160	21	22
SMR 80	328	258	152	25	74	50	117	188	30	32
SMR 125	377	278	170	28	85	55	133	222	41	46
SMR 200	414	317	189	32	90	65	150	242	53	58
SMR 325	468	365	212	42	105	75	166	277	82	92

Technical Data

Selection Procedure

Service Factor

Select the service factor from the application point. Refer table below.

Load classifications	Hours/Day		
	Under 10	10 to 16	Over 16
Uniform	1.0	1.12	1.25
Moderate Shock	1.25	1.4	1.6
Heavy Shock	1.6	1.8	2.0

Design Power

Multiply the absorbed power (or motor power if absorbed power not known) by the service factor chosen in (A).

Unit Selection

Using the value from (B) refer to the power rating table shown below and select the correct size of unit. The choice of single or double reduction gear box will be determined by the output speed required.

Power Rating Table

Output rev/min	Power Ratings (KW) 5:1 Ratio							Output rev/min	Power Ratings (KW) 13:1 and 20: 1 Ratio						
	SMR20	SMR30	SMR50	SMR80	SMR125	SMR200	SMR325		SMR20	SMR30	SMR50	SMR80	SMR125	SMR200	SMR325
100	1.75	2.70	4.22	6.65	10.30	15.15	25.4	10	0.19	0.30	0.50	0.81	1.25	1.98	3.15
110	1.90	2.88	4.65	7.09	11.05	16.09	27.6	12	0.22	0.36	0.56	0.95	1.50	2.46	3.72
120	2.08	3.14	5.05	7.48	11.78	17.02	29.8	14	0.25	0.44	0.66	1.12	1.75	2.72	4.32
130	2.20	3.37	5.33	7.78	12.36	17.86	31.6	16	0.28	0.48	0.78	1.26	1.98	3.10	4.90
140	2.38	3.58	5.56	8.13	12.73	18.61	32.6	18	0.32	0.54	0.86	1.42	2.20	3.45	5.50
150	2.55	3.63	5.79	8.32	13.15	19.23	33.8	20	0.36	0.60	0.97	1.59	2.45	3.84	6.10
160	2.64	3.75	5.89	8.52	13.56	19.97	34.8	22	0.40	0.63	1.05	1.75	2.68	4.20	6.65
170	2.72	3.84	5.99	8.74	13.77	20.38	35.2	24	0.42	0.70	1.14	1.86	2.90	4.57	7.24
180	2.77	3.95	6.08	8.93	14.20	21.01	35.8	26	0.47	0.74	1.24	2.03	3.15	4.92	7.80
190	2.84	4.06	6.31	9.16	14.51	21.55	36.8	28	0.49	0.80	1.33	2.19	3.37	5.25	8.36
200	2.91	4.22	6.51	9.46	14.92	22.06	37.9	30	0.53	0.87	1.43	2.33	3.60	5.65	8.95
210	2.98	4.32	6.54	9.67	15.25	22.48	38.6	32	0.57	0.93	1.51	2.47	3.80	5.98	9.50
220	3.05	4.43	6.73	9.86	15.74	23.10	39.2	34	0.60	0.98	1.60	2.65	4.05	6.35	10.04
230	3.11	4.55	6.86	10.06	16.08	23.65	40.0	38	0.65	1.10	1.80	2.92	4.50	7.06	11.13
240	3.20	4.67	7.06	10.30	16.51	24.27	41.2	40	0.70	1.15	1.86	3.08	4.12	7.42	11.89
250	3.25	4.79	7.16	10.73	16.82	25.06	42.0	42	0.72	1.22	1.96	3.20	4.93	7.77	12.40
260	3.30	4.90	7.36	10.93	17.02	25.41	43.1	46	0.78	1.32	2.14	3.50	5.38	8.30	13.65
270	3.35	5.06	7.47	11.15	17.86	26.26	44.1	50	0.86	1.43	2.30	3.80	5.82	9.08	14.62
280	3.40	5.22	7.57	11.56	18.40	26.80	45.3	52	0.88	1.47	2.36	4.00	6.05	9.15	15.25
290	3.48	5.37	7.78	11.77	18.92	27.43	46.1	54	0.92	1.53	2.47	4.15	6.25	9.45	15.88
300	3.56	5.47	7.99	12.08	19.44	27.84	47.3	58	0.96	1.65	2.61	4.45	6.67	10.03	16.82
310	3.67	5.63	8.18	12.35	19.96	28.68	48.6	62	1.05	1.73	2.78	4.78	7.25	10.64	17.98
320	3.80	5.69	8.31	12.60	20.26	29.60	49.4	66	1.10	1.87	2.95	5.02	7.69	10.64	17.98
330	3.86	5.89	8.51	13.03	12.91	30.36	50.8	70	1.17	1.95	3.08	5.14	8.12	11.78	20.17
340	3.95	6.08	8.71	13.43	21.10	31.09	52.2	74	1.23	2.05	3.18	5.45	8.55	12.40	21.13
350	4.07	6.31	8.83	13.77	21.86	31.72	53.3	78	1.30	2.16	3.34	5.71	8.98	12.95	22.28
360	4.17	6.49	9.04	14.19	22.46	34.60	54.6	80	1.32	2.24	3.39	5.82	9.10	11.25	22.48
370	4.25	6.62	9.25	14.45	22.80	33.60	55.6	85	1.38	2.35	3.59	6.15	9.70	13.98	23.32
380	4.34	6.73	9.44	14.71	23.09	34.49	56.77	90	1.48	2.50	3.80	6.50	10.25	14.62	24.58
390	4.45	6.94	9.55	15.25	23.53	34.07	58.9	95	1.57	2.63	4.00	6.82	10.50	15.45	25.85
400	4.52	7.15	9.68	15.66	24.58	35.92	59.8	100	1.65	2.75	4.20	7.20	11.05	16.20	27.12

Gearbox Installation

Gearbox performance depends on proper installation, lubrication and maintenance.

Install pulley on gearbox input shaft as close to the reducer as possible. Failure to do this will cause excess load on the input shaft bearings and could cause their premature failure.

Install motor and wedge belt drive with the belt pull at approximately 90° to the centerline between driven and input shafts.

Install torque-arm fulcrum on a rigid support. Make sure there is sufficient take up in the turnbuckle for belt tension adjustment.

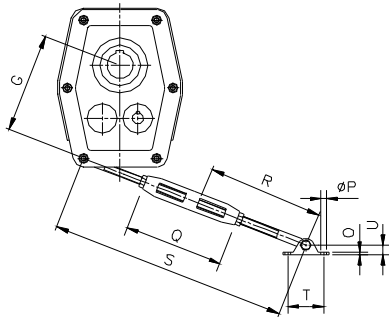

Model	S		R	Q	O	T
	Min	Max.				
SMR 20	600	750	300	200	5	65
SMR 30	600	750	300	200	5	65
SMR 50	600	750	300	200	5	65
SMR 80	700	850	350	216	5	75
SMR 125	700	850	350	216	5	75
SMR 200	750	900	375	216	6	100
SMR 325	750	900	375	216	6	100

Lubrication

Shaft Mounted Reducers are dispatched without oil. Before running they should be filled with an appropriate amount of the lubricant.

Recommended Lubricants

Brand	Oil
Indian Oil	Servomesh 150
Hindustan Petroleum	GER VIL EP 150

Mounting Positions

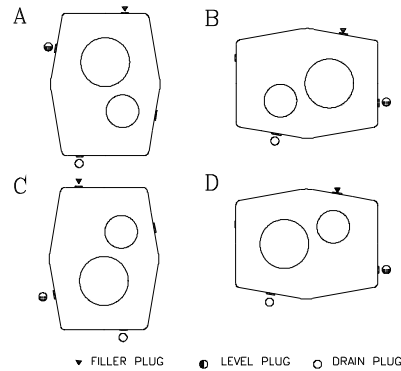

Oil Quantities (Liters)

Model	Mounting Position			
	A	B	C	D
SMR 20	0.3	0.35	0.3	0.4
SMR 30	0.35	0.45	0.4	0.5
SMR 50	0.55	0.65	0.6	0.75
SMR 80	0.9	1.40	1.20	1.40
SMR 125	1.8	2.0	1.8	1.9
SMR 200	2.5	2.5	2.5	2.5
SMR 325	3.5	4.0	3.5	4.5

Product Range

- | | | |
|---|--|--|
| <ul style="list-style-type: none"> • Planetary Drives • Cycloidal Drives • Track Drives • Worm Drives • Creep Drives | <ul style="list-style-type: none"> • Wheel Drives • Centrifuge Drives • Torque Limiter • Differential Drives • SMP / SMR Drives | <ul style="list-style-type: none"> • Elevator Drives • Slew Drives • Pump Drives • Helical Geared Motor • Custom Built Drives |
|---|--|--|

For technical clarifications and detailed catalogue please contact us at



Cyclo Transmissions Ltd.
At and Post Patkhal,
Tal and Dist Satara 415 011
Maharashtra - INDIA

Phone : (02162) 231939, 230185
Fax : (02162) 232219, 245060
E- mail : marketing@cyplagear.com
satara@cyplagear.com
Visit us at : www.cyplagear.com